

SST2[™]

SYSTEM SERVICE TRANSITION

The industry's only compact, knock-down, system transition with an access door large enough to allow proper inspections and maintenance.

NO MORE SMALL "INSPECTION" DOORS.

Extra-large door allows true access for inspections, cleaning, leak detection, heat exchanger inspection, and system checks.

FITS MULTIPLE APPLICATIONS.

Side Access Series and Closet Series models are available.

OPTIMIZED SEER PERFORMANCE PLUS EASY SERVICE SOLUTION.

The SST2[™] System Service Transition solution allows for quick and efficient HVAC system service, while optimizing SEER performance with improved laminar flow distribution.



GENERAL

The SST2™ is designed to optimize SEER performance by improving laminar flow distribution. The removable, insulated, access door, gives the servicing contractor the space they need to properly inspect, clean, diagnose and maintain the evaporator coil and the furnace heat exchanger. The SST2™ provides true access to the system critical parts without disassembly or cutting into the system.

SPECIFICATIONS

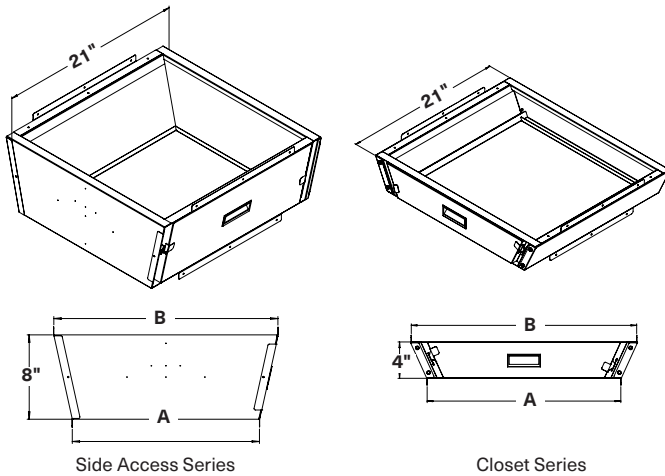

DESCRIPTION	PART #		DIM A (In)	DIM B (In)
	SIDE ACCESS	CLOSET		
A Cabinet Furnace to A Cabinet Coil	19830	19840	14.00	14.25
A Cabinet Furnace to B Cabinet Coil	19831	19841	14.25	17.75
A Cabinet Furnace to C Cabinet Coil	19832	19842	14.25	21.25
B Cabinet Furnace to B Cabinet Coil	19833	19843	17.50	17.75
B Cabinet Furnace to C Cabinet Coil	19834	19844	17.75	21.25
B Cabinet Furnace to D Cabinet Coil	19835	19845	17.75	24.75
C Cabinet Furnace to C Cabinet Coil	19836	19846	21.00	21.25
C Cabinet Furnace to D Cabinet Coil	19837	19847	21.25	24.75
D Cabinet Furnace to D Cabinet Coil	19838	--	24.50	24.75

*All models ship in knock-down format. Side Access Series - 4" x 26" x 10". Specifications subject to change without notice.

IAQ READY (Side Access Series only.)

The SST2™ comes with pre-drilled pilot holes behind the mounting template, allowing for easy installation of Dust Free® indoor air quality purifiers.

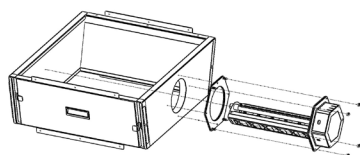

Active™ and Carbon™ Air Purifiers

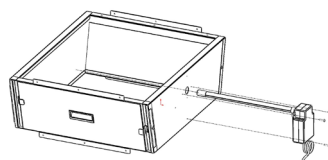

Lightstick™ and Lightstick™ Plus
 Germicidal UV Systems

FEATURES

- **Optimized SEER performance and air distribution.** The SST2™ improves laminar flow distribution without block-offs or restrictions. Compatible with 2023 SEER2 standards.
- **Large access door for easy system inspection and maintenance.** The SST2™ provides true access to critical system components.
- **Saves time and labor.** No more time spent dismantling or cutting into a system for service. No more time spent re-assembling and resealing the system afterward.
- **“Knock-down” format makes the SST2™ easy to carry into tight spaces and field assemble in minutes.**
- **Door and panels come lined with foil-backed, UV-safe, R4.3 insulation that meets application standards and code compliance for HVAC accessories.**
- **Available in sizes for upflow, horizontal, attic, basement, and closet applications.**
- **SST2™ Side Access Series comes with pre-drilled pilot holes behind the mounting template, allowing for easy installation of Dust Free® indoor air quality purifiers.**